

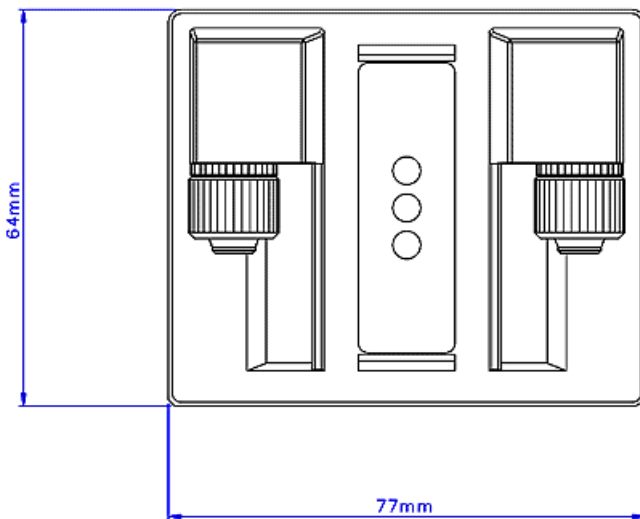

New technology has allowed Koolance to advance its patented design even further, now for heat sources of up to 300W! The CPU-300 uses a high density gold-plated copper cold plate with a cover of heavy engineering resin.

The IPC 1U rack-compatible CPU-300-H06 natively supports processors with Intel socket 478, AMD socket 462/A, and Intel socket 370. With separate adapters, it can also support AMD AM2/AM2+/AM3, AMD 939/940/754, Intel LGA-775, and Intel 603/604. The CPU-300 has threaded compression fittings for easy assembly.

General	
Weight	1.00 lb (0.45 kg)



Thermal Resistance vs. Flow Rate

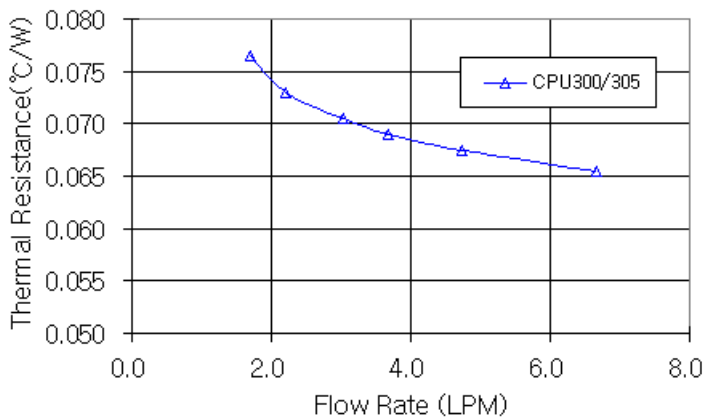

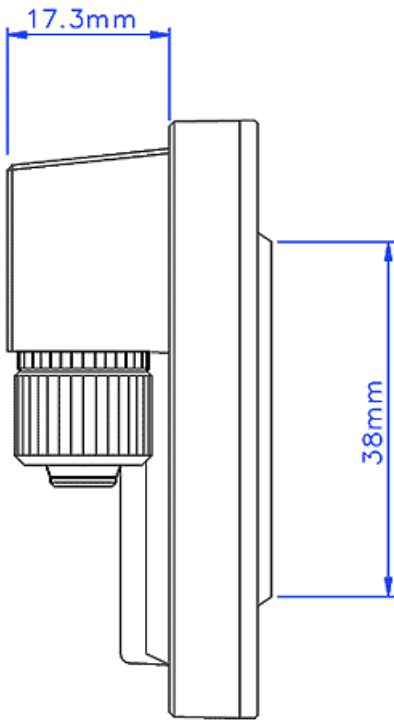
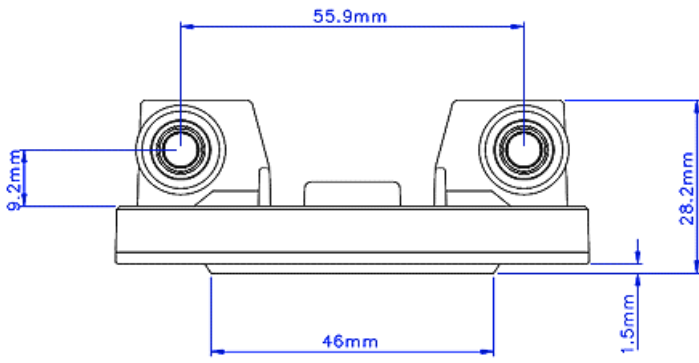

Pressure Drop vs. Flow Rate

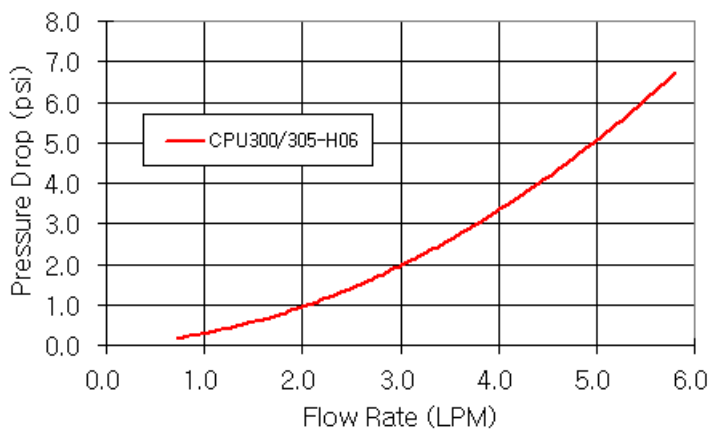

Thermal Resistance vs. Pressure Drop

