

ERM-2K3UCU Liquid Cooling System, Copper Rev1.1



The ERM-2K3U continues Koolance's "ERM" series of dedicated liquid cooling systems for special thermal applications. It can provide up to approximately 2000W of potential heat dissipation. A prominent white LED-lit reservoir displays the coolant level, combining a waterfall effect when placed upright. **ERM-2K3UCU Rev.1.1** has several new features:

- Copper core heat exchanger
- [PMP-450S](#) pump running at **24V**
- Independent 110V/220V AC power supply
- Front facing power and tank illumination buttons (must use power button to turn unit on/off)
- Includes carrying handle

Heat sources from multiple computers can be connected to a single ERM-2K3U system if within the total dissipation rating. A large louver-fin heat exchanger stretches diagonally from front to back, cooled by two 220mm blue LED side fans, and five low-flow 80mm rear fans.

The cooling system can be positioned in multiple ways. Post feet are included for vertical tower and horizontal orientations (with fans facing up or down). Alternatively, the unit fits within a 3U profile and rack mountable ears are included. The LED readout can be conveniently rotated for these positions. (NOTE: 3 bottles of coolant is recommended for the ERM-2K3U.)

Other features:

- Variable pump speed via the front display
- Rear G 1/4 BSPP inlet and outlet fitting sockets
- Radiator fan speeds adjust automatically, or with 10 manual levels
- White reservoir LED lighting (can be switched on or off)
- Top coolant fill plug
- Independently-variable alarm and safety shutdown temperatures on all three sensors
- Integrated switching power supply - requires 110VAC or 220VAC

General	
Weight	28.60 lb (12.97 kg)
Cooling Systems	
Display Type	LED
Fans	2 x 220mm (81CFM), 5 x 80mm (210CFM)
Max Flow Rate (10-13mm ID)	PMP-450S @ 24V
Power Source	110/220 VAC
Radiator	Brass/Copper
Temperature Sensors	50K Thermistors

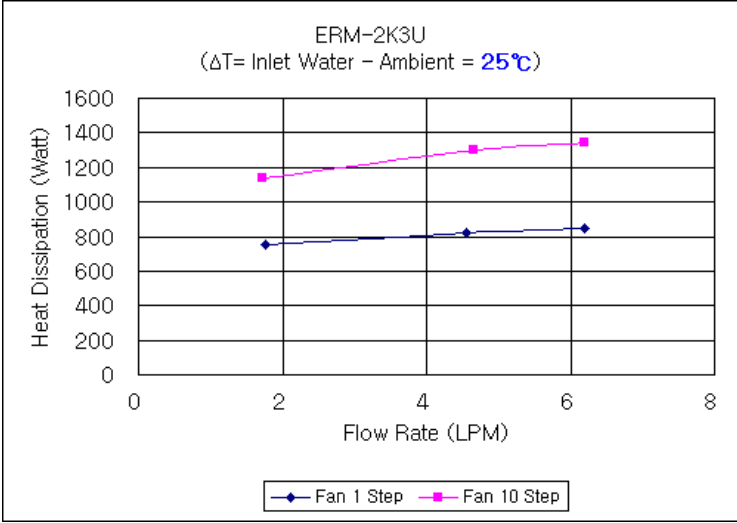
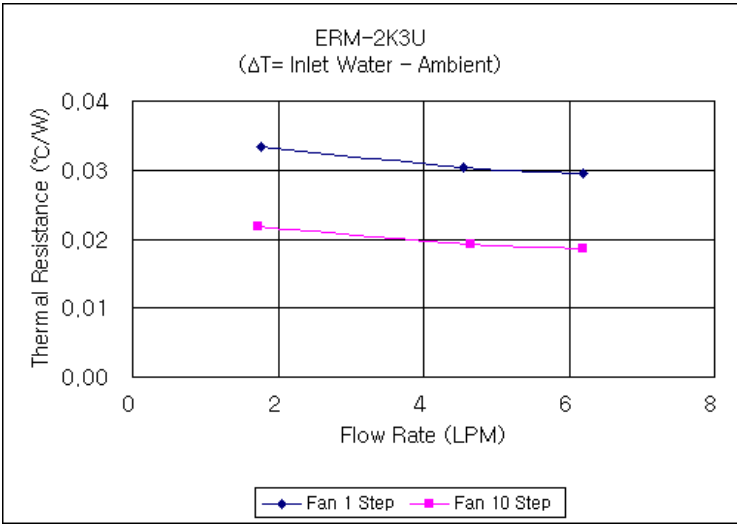

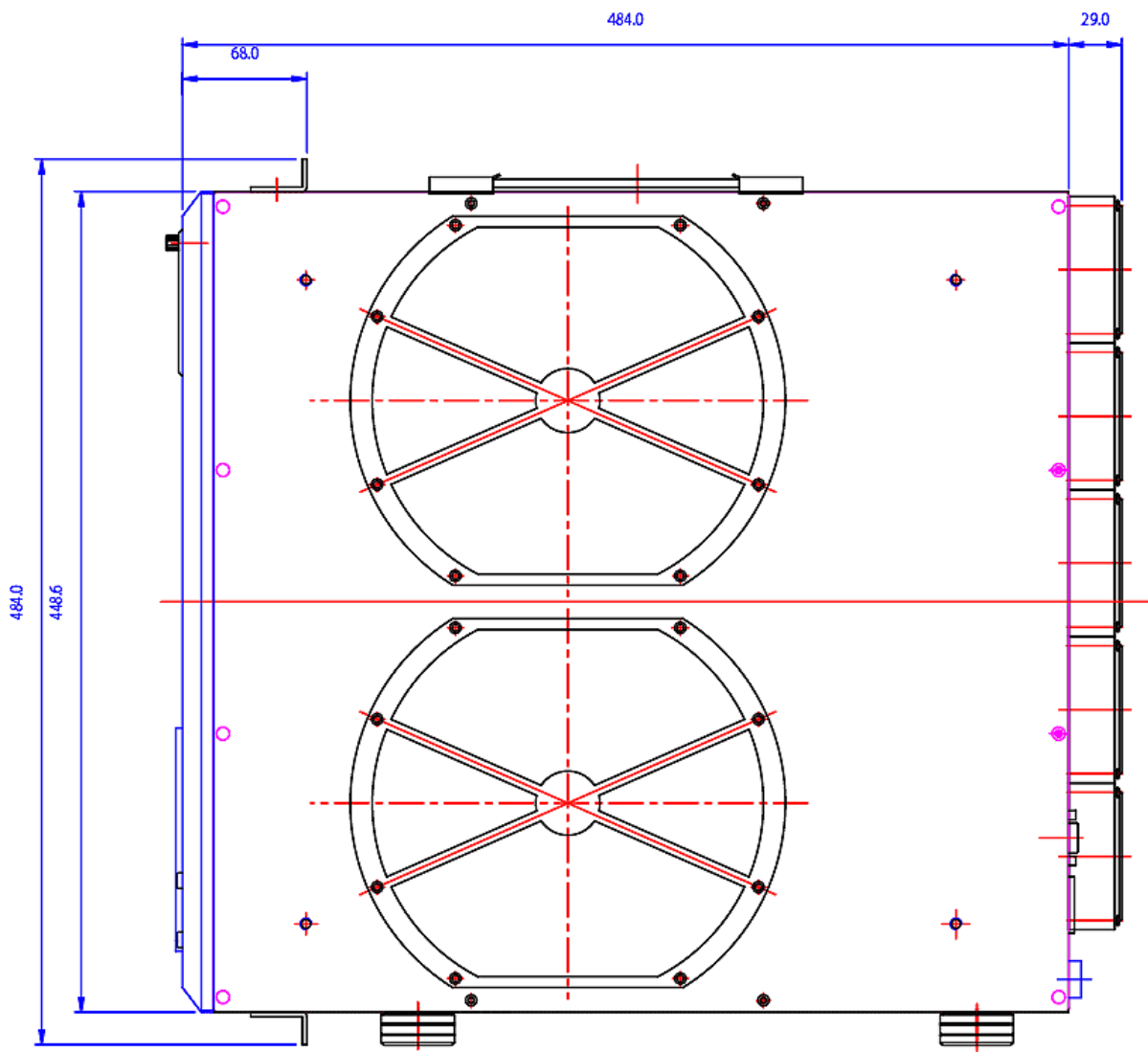

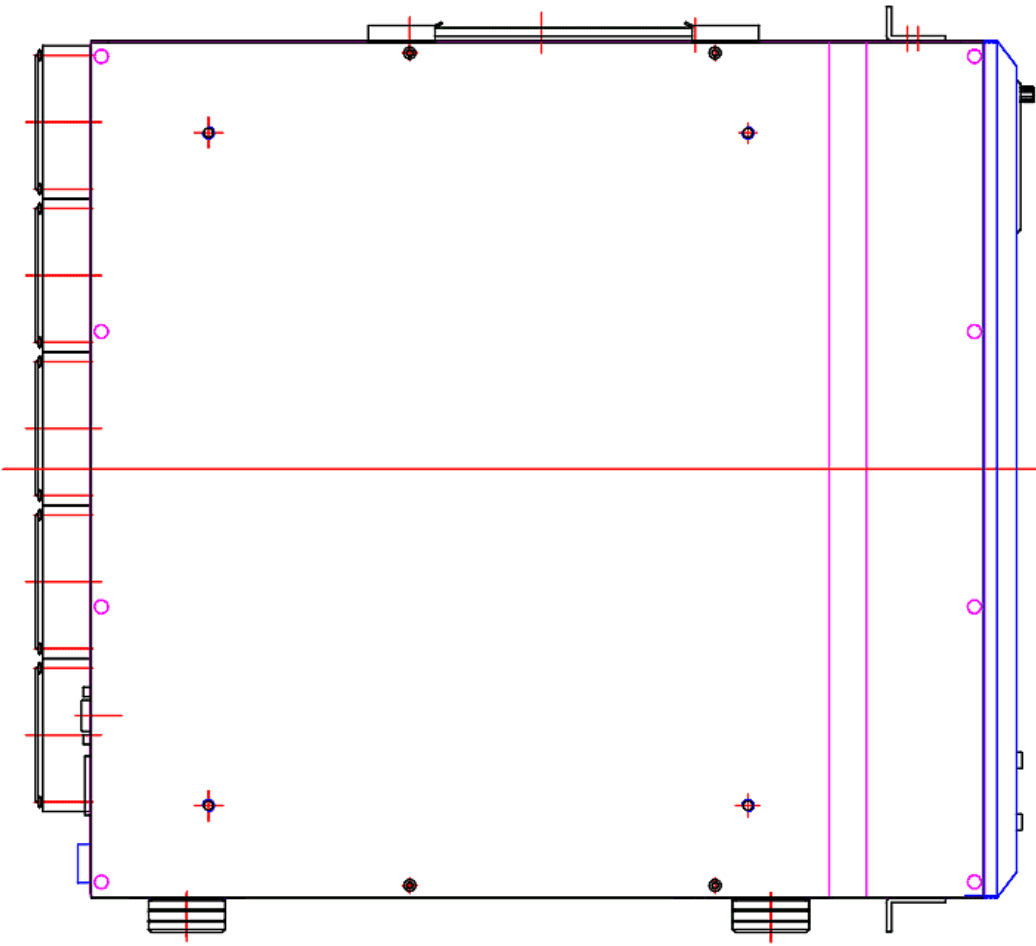

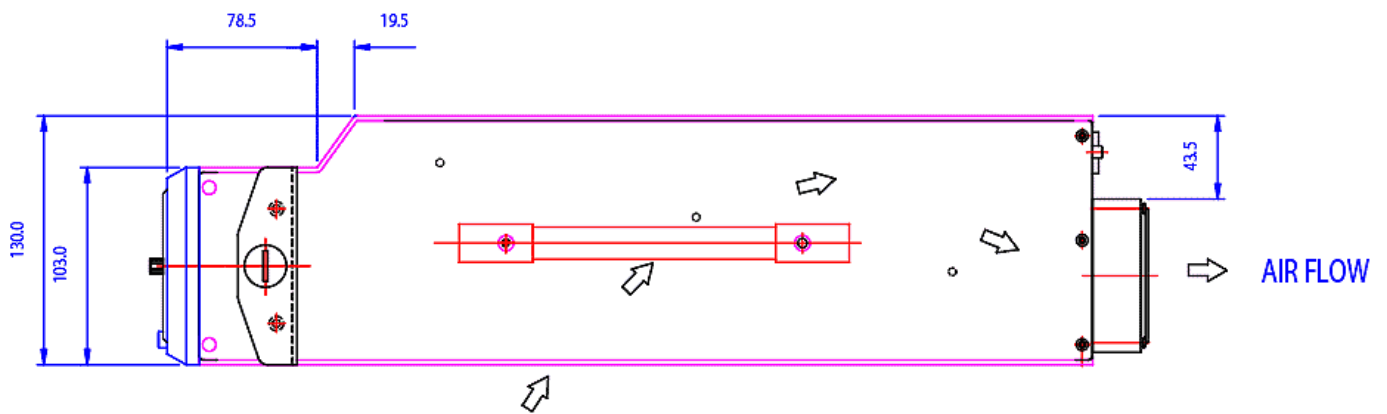
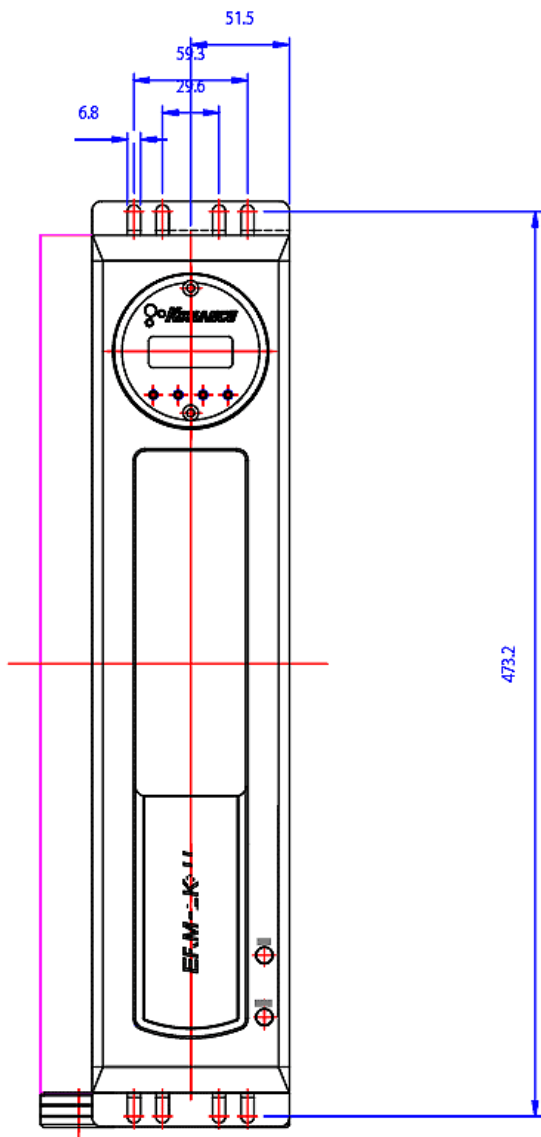

TOP VIEW

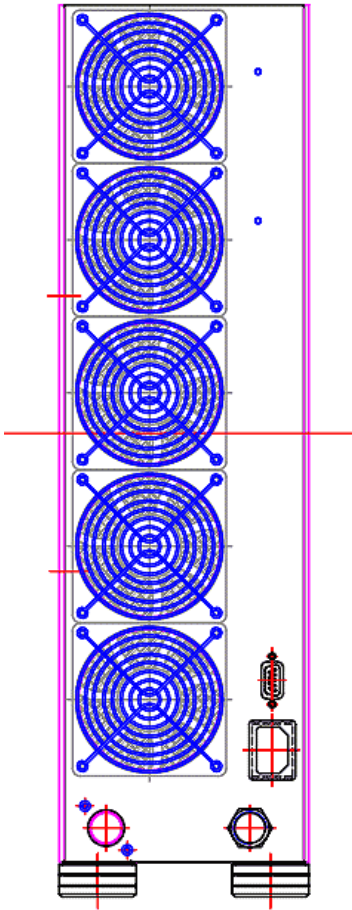

REAR VIEW



BOTTOM VIEW

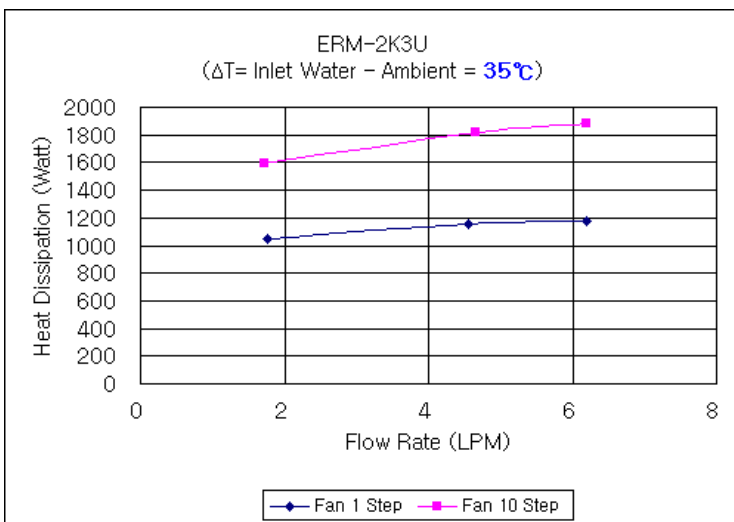

ERM-2K3U Radiator

