

NUT

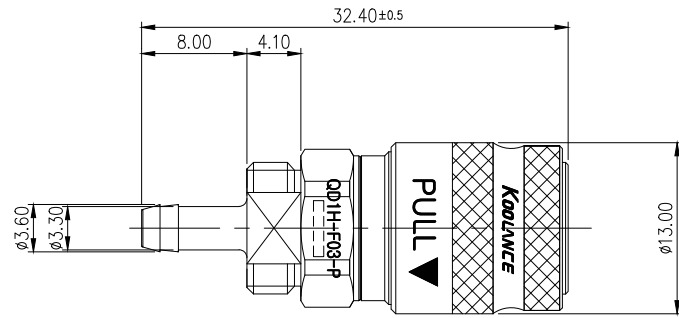
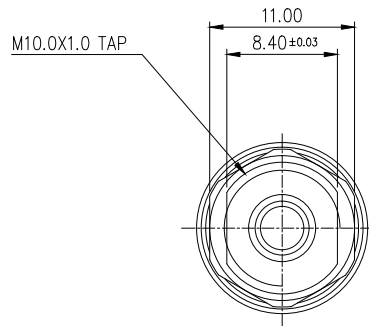

REV	DATE	CONTENTS	REVD BY	CHKD BY	APPD BY
REVISION					

NO.	DESCRIPTION				MATER'L		QUANTITY	REMARKS
	<b>KOOLANCE</b>	DECIMAL PLACES	INCHES	MILLIMETERS	UNIT	MM	ITEM	QD1H
		.XXX .XX .X	±.005 ±.010 ±.020	±0.1 ±0.3 ±0.5	SCALE	N/S	TITLE	QD1H-F03-P
DATE	BY	BY	BY	APPRO	BY	3RD ANGLE		
	SONG					CODE NO.	DWG. NO.	PAGE
						SURFACE ROUGHNESS	SURFACE	SURFACE
						.63	1.6	