



The GPU-210 is a general-purpose block with a 0.5mm microfin internal structure. The cooling area footprint is 35mm x 35mm (1.4in x 1.41in). Materials include a copper cold plate, brass top, anti-corrosive nickel plating, and EPDM o-ring. Works with G 1/4 BSPP (parallel) thread fittings.

Redundant side and top inlet/outlet fitting sockets allow for more flexibility during installation. Two fitting socket plugs are included.

Four combination sets of brackets are included for various mounting situations, which adjust for diagonal mounting hole distances from approximately 54mm to 85mm (2.1in to 3.3in).

Cold Plates	
Flow Resistance @ 5LPM (10-13mm ID)	0.042kgf/cm ² (0.6psi)
Thermal Resistance @ 5LPM (Approx.)	0.055° C/W
General	
Weight	0.41 lb (0.19 kg)
Materials	Nickel-Plated Copper, Nickel-Plated Brass, EPDM
Max Pressure Tolerance @ 25° C	10kgf/cm ² (142.2psi)
Max Temp. Operating Tolerance	100° C (212° F)

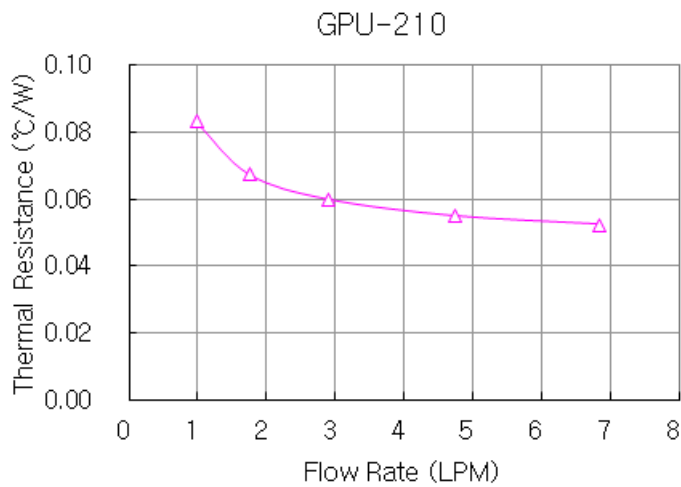

GPU-210

