

HXM-ALX2000 Heat Exchanger Module for ALX Series

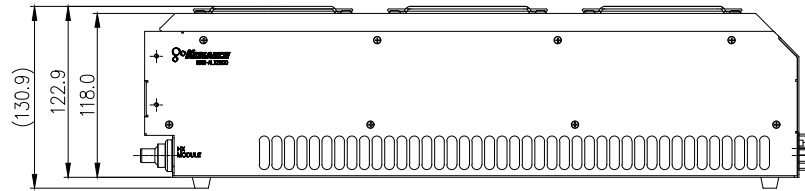

HXM-ALX2000 is a triple fan heat exchanger for Koolance's [ALX modular cooling systems](#). When combined with an [RPM reservoir and pump module](#) (sold separately), the heat dissipation is approximately 2000W. Front fitting threads are G 1/4 BSPP, and the rear are 1/4 NPT.

General	
Weight	7.40 lb (3.36 kg)
Fitting Thread	G 1/4 BSPP (front), NPT 1/4 (back)
Wetted Materials	Brass/Copper
Cooling Systems	
Cooling Capacity	2000W (6824BTU/hr) @ 25° C liquid-ambient (when combined with RPM-ALX400)
Radiators	
Fan Capacity	3 x 120mm

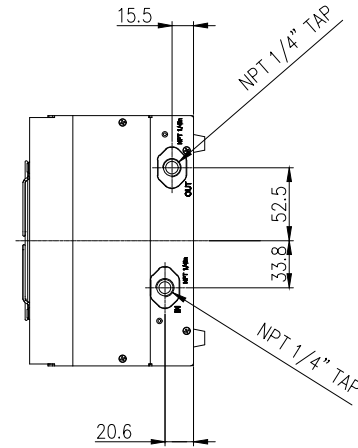
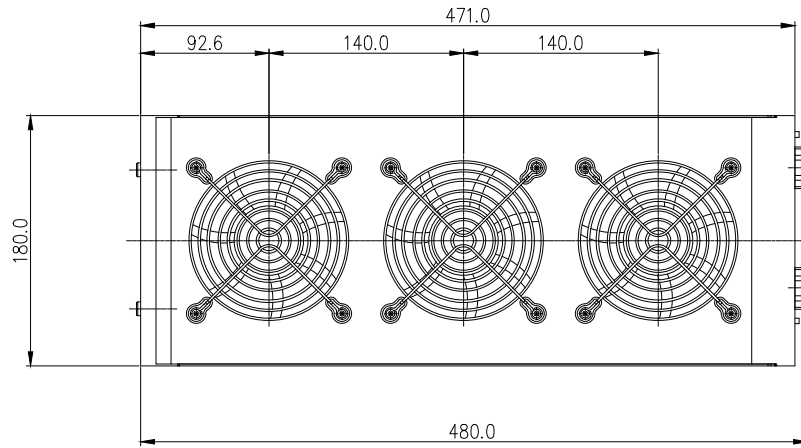
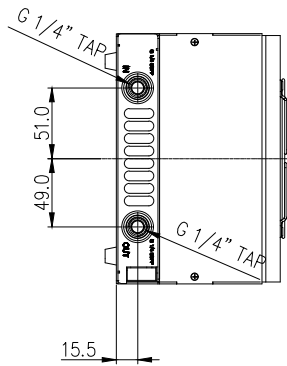
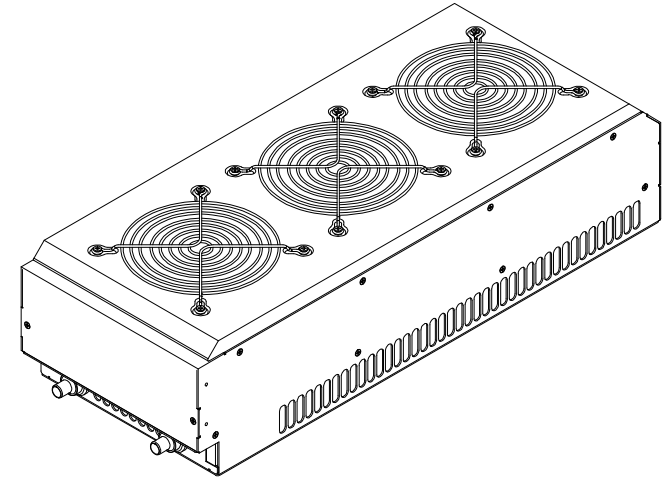
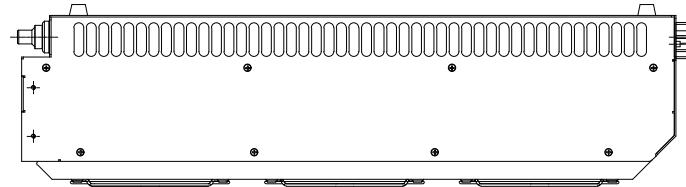

NO.	DISCRIPTION				MATER'L		QUANTITY	REMARKS
					UNIT	MM		
					SCALE	N/S	TITLE	Ass'y
DATE				APPRO	3RD ANGLE			
MAR.13.2026	S.J.LEE				CODE NO.		DWG. NO.	PAGE