

**Tubing Ear Clamp for OD 17mm (11/16in) - [100 Pack]**

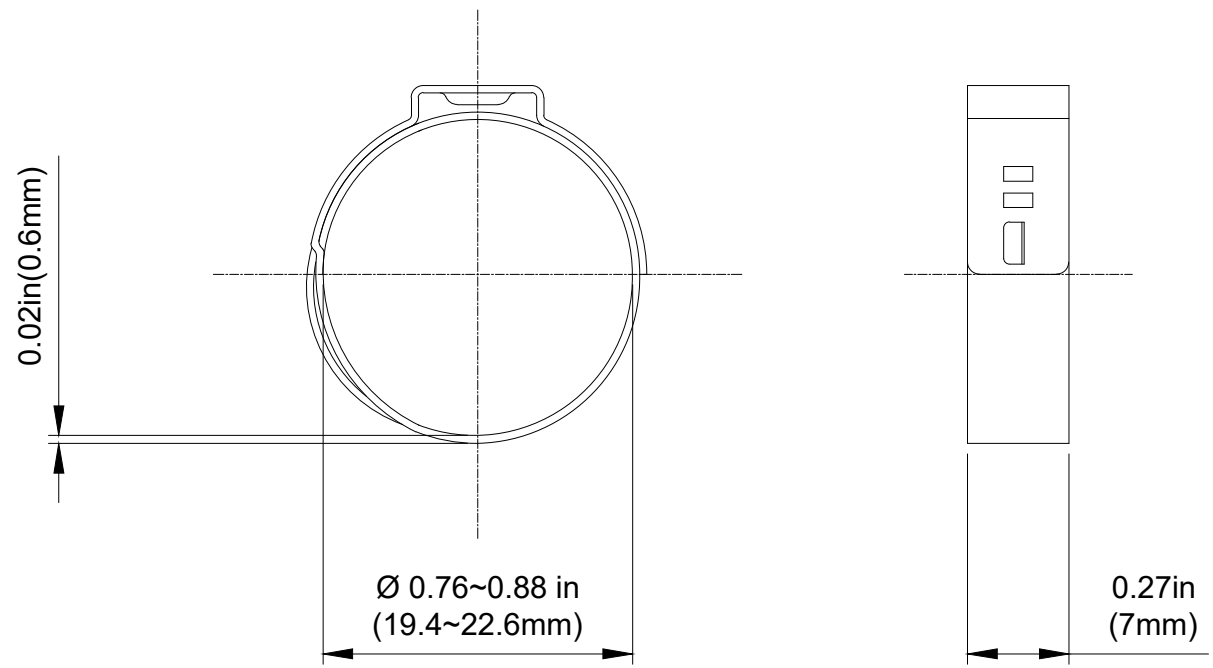

100 pack of single-use ear clamps for 17mm (11/16in) OD tubing and hose. An ear crimping tool is required for these clamps.

General	
Weight	0.75 lb (0.34 kg)



Stainless steel (AISI 304)

NO.	DESCRIPTION					MATER'L		QUANTITY	REMARKS
						UNIT	MM		
						SCALE	N/S	TITLE <b>CLM-17E-xx</b>	
DATE						BY	BY		
2026.05.11	SK.An				CODE NO.		DWG. NO.		