

**Tubing Ear Clamp for OD 21mm (13/16in) - [100 Pack]**

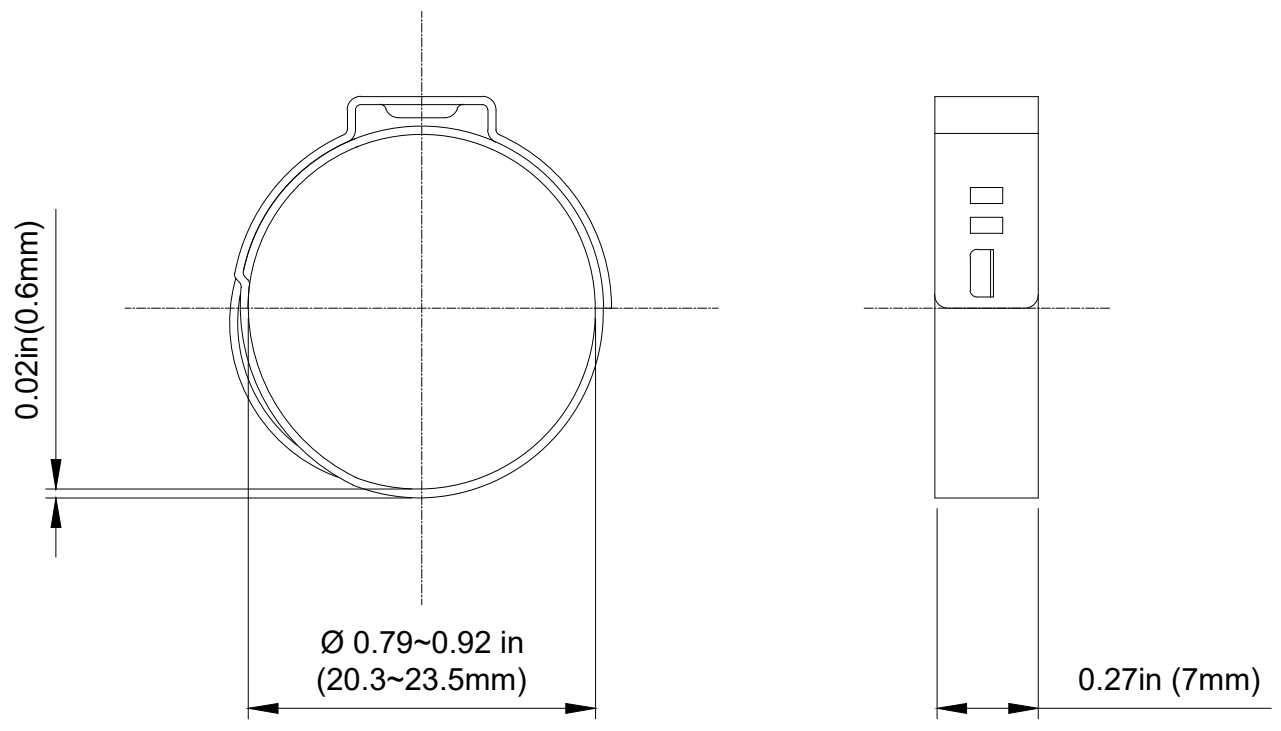

100 pack of single-use ear clamps for 21 mm (13/16in) OD tubing and hose. An ear crimping tool is required for these clamps.

General	
Weight	0.81 lb (0.37 kg)



Stainless steel (AISI 304)

NO.	DESCRIPTION				MATER'L		QUANTITY	REMARKS
					UNIT	MM	APPAR	
					SCALE	N/S	TITLE	
DATE	BY	BY	BY	APPRD BY	3RD ANGLE		<b>CLM-21E-xx</b>	
2026.05.11	SK.An				CODE NO.	DWG. NO.		