



ALR-4500 is Koolance's highest performing ambient liquid cooling system. It can be oriented in horizontal or vertical orientations, and is rack-mountable. This model contains a large eight x 120mm fan aluminum radiator, providing roughly 4300W of cooling with a 25°C ambient delta. Coolant flow rate, temperature, and reservoir level are monitored, and a USB port allows control and logging of most features using the [Koolance System Monitor](#) application.

- Cooling capacity: 4300W (14,672BTU/hr) with 25°C liquid-ambient delta @ 9LPM
- Temperature in °C/°F with set-point based on: liquid (-30 to 90°C), or one of two optional K-type thermocouples (-20 to 120°C)
- Pump: 10 manual levels, up to 10.5LPM (2.8GPM)
- Select only values you want displayed on the front 2-line

OLED display (fixed or rotating)

- Show coolant flow rate in LPM/GPM
- Show pump impeller speed in RPM
- Enable audio alarm based on: temperature, flow rate, and/or reservoir coolant level
- Enable relay trigger (NO or NC) based on: temperature, flow rate, and/or reservoir coolant level
- Power input: 110/220VAC, 50-60Hz
- Max power consumption: 220W
- Reservoir capacity: 2.5l (0.66gal)
- NPT 1/4in threads on back for fittings

The cooling system can be positioned in multiple ways. Feet are included for vertical tower or horizontal orientations, with fans facing up or down. The unit also fits within a 3U profile and includes rack mountable ears. The front display can be rotated for these positions by hand. NOTE: 3 x 700mL bottles of coolant are recommended for this system.

General	
Weight	28.60 lb (12.97 kg)
Fitting Thread	NPT 1/4
Max Pressure @ 25°C	2kgf/cm2 (28.5psi)
Max Temp. Operating Tolerance	60°C (140°F)
Noise (dBA)	49-71
Cooling Systems	
Cooling Capacity	4300W (14,672BTU/hr)
Display Type	OLED
Flow Rate	10.5LPM (2.8GPM)
Max Power Consumption	220W
Power Source	110/220 VAC, 50-60Hz
Radiator	Aluminum, 8 x 120mm fans
Temperature Sensors	Liquid & Two K-Type Thermocouples (optional)

General	
Temperature Stability	+/-0.5°C

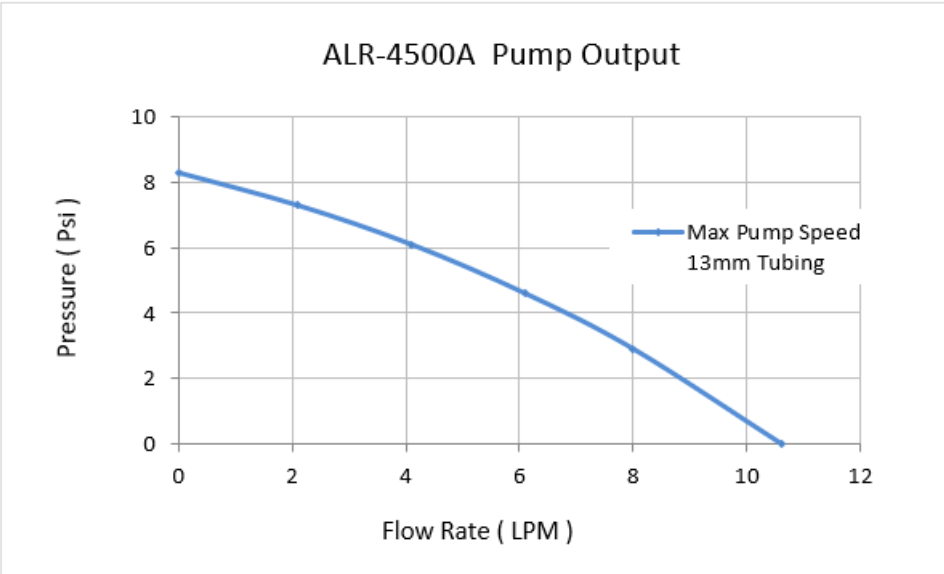
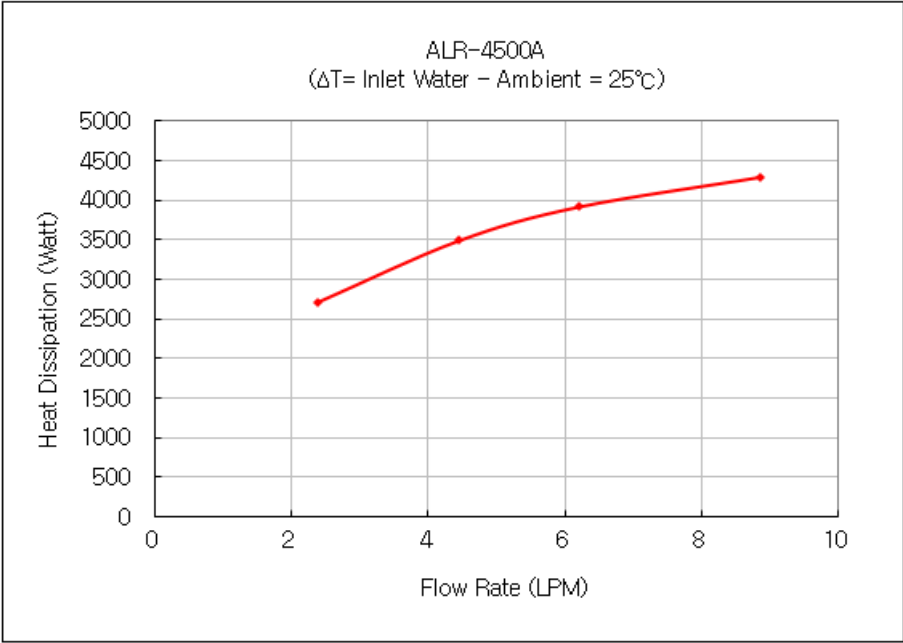

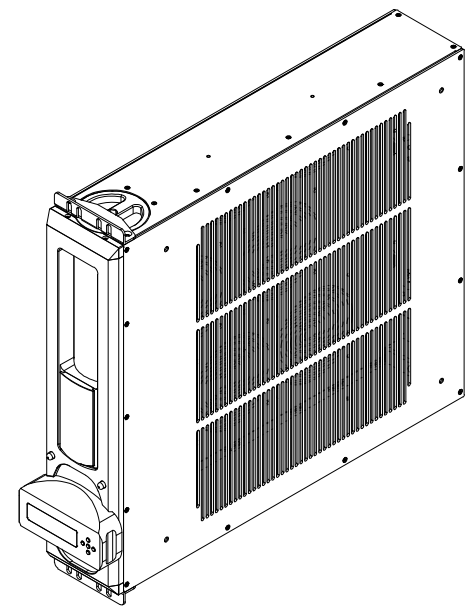
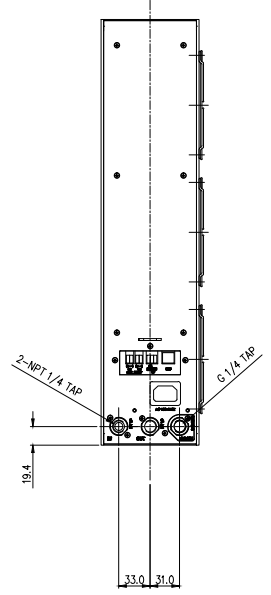
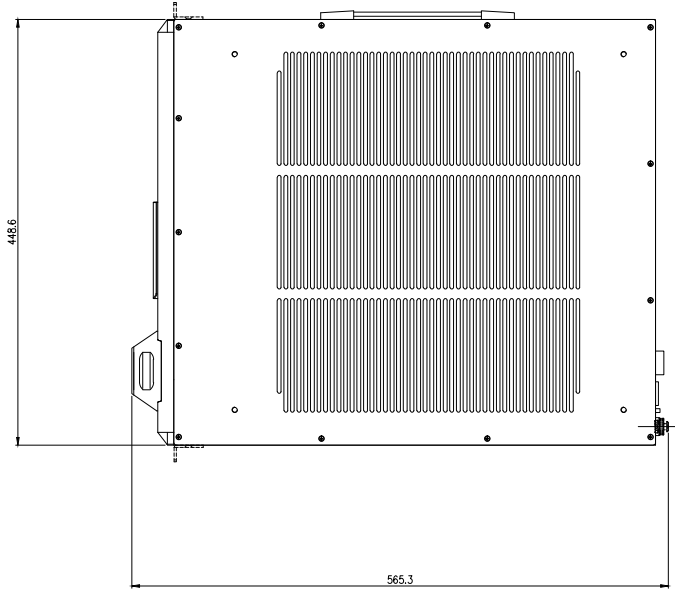
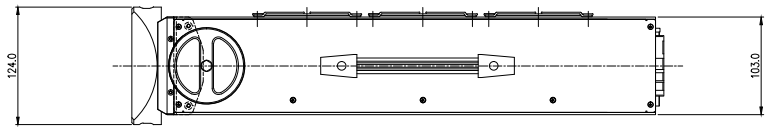
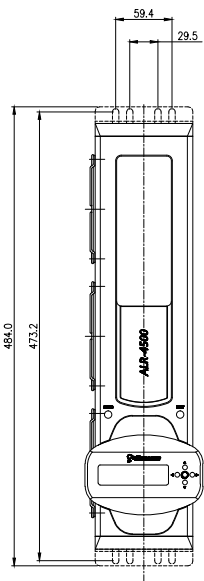

NO.	DESCRIPTION	MATER'L		QUANTITY	REMARKS
	KOOLANCE	UNIT	MM	ITEM	ALR-4500
		SCALE	N/S	TITLE	
DATE	BY	BY	APPRO BY	Ass'y	
	S.J.LEE			CODE NO.	DWG. NO.
					PAGE