

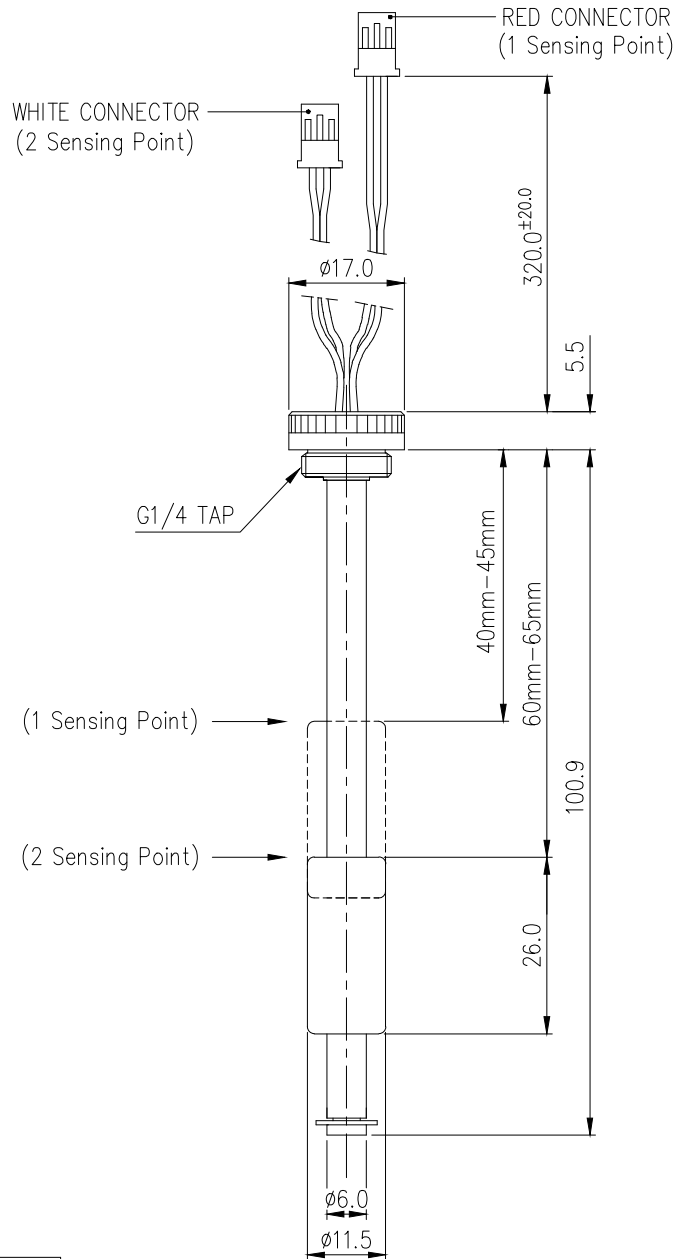

Koolance liquid dual level sensor with column float and two 2-pin connectors. Circuits are normally open until float reaches the middle (red connector) and bottom (white connector) of the metal column. Total length = 100mm. Nickel plated brass, G 1/4 BSPP threading.

NOTE: SEN2-LVL100 has two magnetic reed open/close contact switches intended for signals in the 50-100mA range. It should not be used on higher power outputs like fan headers or controllers.

General	
Weight	0.08 lb (0.04 kg)
Fitting Thread	G 1/4 BSPP
Max Pressure Tolerance @ 25 °C	10kgf/cm2 (142.2psi)
Max Temperature Tolerance	80 °C (176 °F)
Wetted Materials	Nickel-Plated Brass, Stainless Steel, PP, EPDM, SmCo5



- Momentary NO magnetic switches which activate when the float reaches their location.
- Contact Rating : 10VA max.
- Switching Voltage : DC/AC 100V max.
- Switching Current : 0.5A max.

REV	DATE	CONTENTS	REVD BY	CHKD BY	APPD BY
REVISION					

NO.	DESCRIPTION	MATER'L	QUANTITY	REMARKS
KOOLANCE		UNIT	MM INCH	APPAR SEN2-LVL100
		SCALE	N/S	TITLE
DATE	BY	BY	BY	BY
3RD ANGLE			100mm, 2 LEVEL SENSOR DIM	
CODE NO.			DWG. NO.	
S.J.LEE				