

**TLH-300 Thermoelectric Liquid Chiller with Heater**



The TLH-300 is a recirculating thermoelectric liquid chiller rated at 300W, or 1024 BTU/hr (@25°C liquid & ambient). The liquid temperature accuracy is precisely controlled to +/- 0.1°C based on a single configurable set point. The system also has heating capabilities to target temperatures above ambient.

TLH-300 has a unique dual reservoir design. The primary loop circulates coolant externally for the cooling/heating application, while the internal loop regulates the thermoelectric components. (Coolant is required in both reservoirs since they are not shared.)

Coolant flow rate, temperature, and reservoir level are monitored, and a USB port allows control and logging of most features using the [Koolance System Monitor](#) application. A 0-5V differential voltage output is also provided for industrial process monitoring.

- Cooling capacity: 300W (1024BTU/hr) @ 25°C liquid/ambient
- Temperature options: liquid set-point (+/-0.1°C accuracy); toggle °C/°F
- Pump: 10 manual levels, up to 8.5LPM (2.2 GPM)
- Select only values you want displayed on the front 2-line OLED display (fixed or rotating)
- Show liquid temperature, and two optional external K-type thermocouples
- Show pump impeller speed in RPM
- Show coolant flow rate in LPM/GPM
- Show radiator fan speed in RPM
- Adjust audio alarm and relay trigger (NO or NC) based on: temperature, flow rate, coolant level, pump RPM, and radiator fan RPM
- Maximum power consumption: 720W
- Reservoir capacity: total 1.8 liters (0.8L external loop, 1L internal loop)
- NPT 1/4in threads for fittings
- Includes C13 to NEMA 5-15 power cord

General	
Weight	43.20 lb (19.60 kg)
Fitting Thread	NPT 1/4in
Max Pressure Tolerance @ 25°C	2kgf/cm2 (28.5psi)
Max Temperature Tolerance	60°C (140°F)
Min Temperature Tolerance (*No Freezing)	-20°C (-4°F)
Noise (dBA)	47
Cooling Systems	
Cooling Capacity	300W (1024BTU/hr) @ 25°C liquid & ambient (0°C dT)
Display Type	OLED
Max Flow Rate (10-13mm ID)	8.5LPM (2.2 GPM)
Max Power Consumption	720W

General	
Max Static Pressure (10-13mm ID)	0.89kgf/cm2 (12.7psi)
Power Source	100-240VAC, 50-60Hz
Temperature Sensors	Liquid & Two K-Type Thermocouples (optional)
Temperature Stability	+/-0.1°C

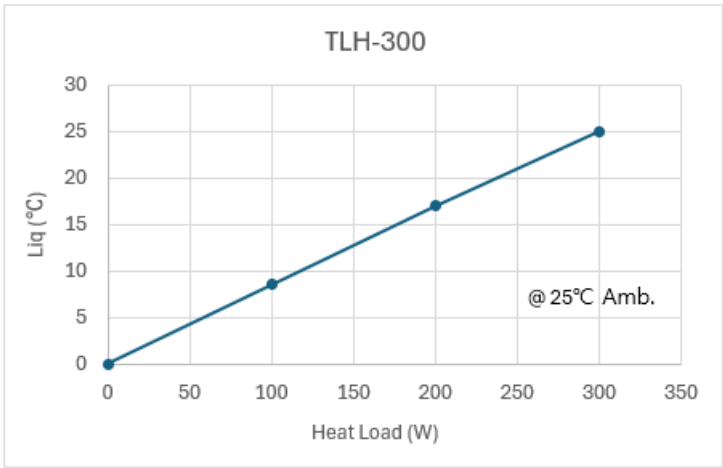
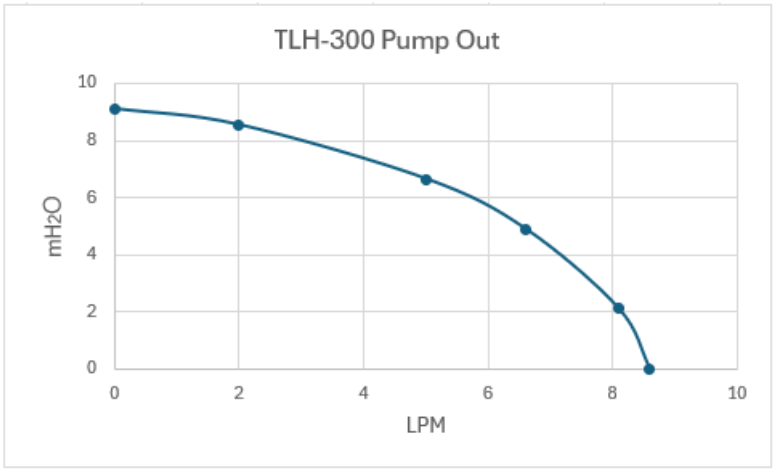

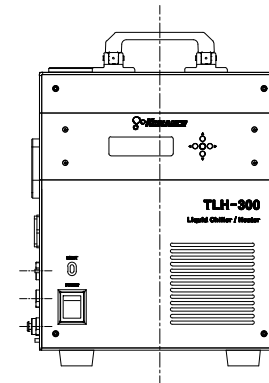
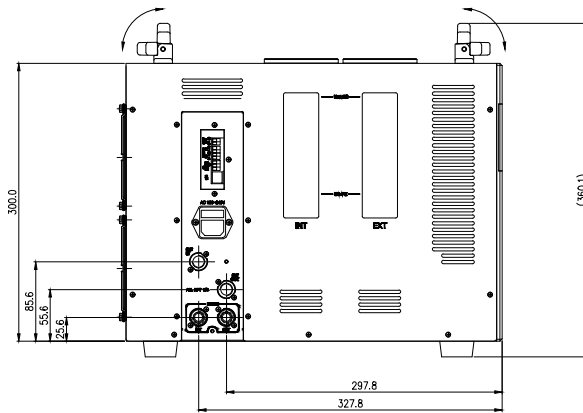
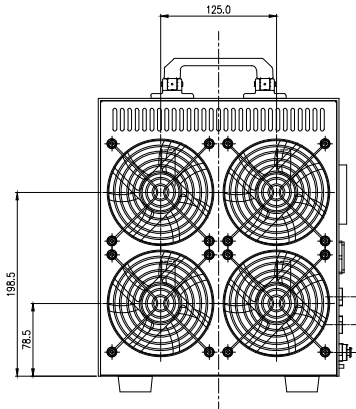
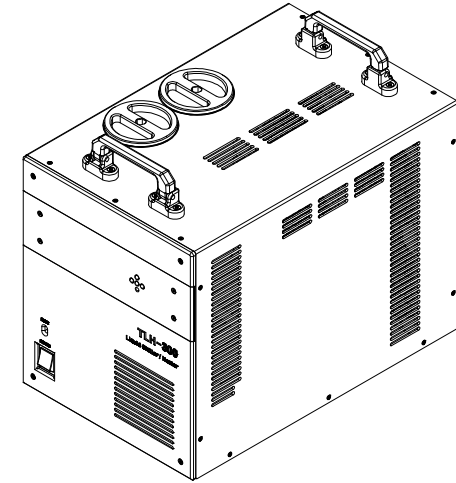
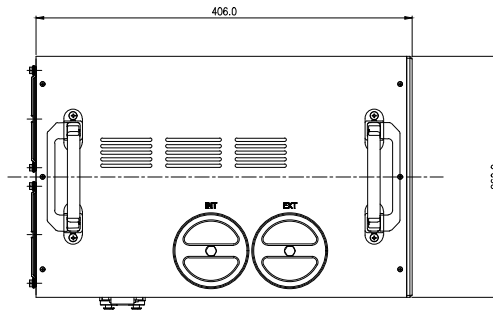
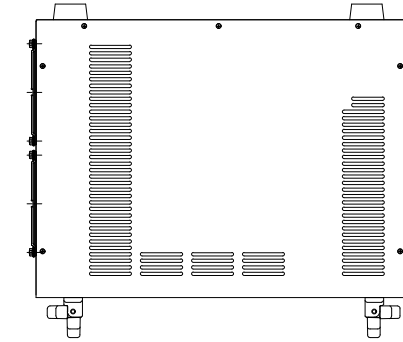

NO.	DESCRIPTION				MATER'L		QUANTITY	REMARKS
					UNIT	MM		
					SCALE	N/S	TITLE	Ass'y
DATE					BY	BY	BY	
	S.J.LEE					CODE NO.	DWG. NO.	PAGE