

EXC-900 Portable 900W Recirculating Liquid Chiller, 220VAC /50-60Hz



Koolance's EXC-900 is a portable recirculating liquid chiller rated at 900W, or 3071 BTU/hr (@25°C liquid & ambient). Chiller control is based on one of four configurable temperature set-points, including the option to lock liquid to ambient for avoiding condensation or to an external K-type thermocouple sensor (not included).

Coolant flow rate, temperature, and reservoir level are monitored, and a USB port allows control and logging of most features using the [Koolance System Monitor](#) application. A 0-5V differential voltage output is also provided for industrial process monitoring.

- Cooling capacity: 900W (3071BTU/hr) @ 25°C liquid/ambient
- Temperature options: liquid set-point, external thermocouple set-point, liquid and ambient delta-T, external thermocouple and ambient delta-T; toggle °C/°F
- Pump: 10 manual levels, up to 11LPM (2.9 GPM)
- Select only values you want displayed on the front 2-line OLED display (fixed or rotating)
- Show pump impeller speed in RPM
- Show coolant flow rate in LPM/GPM
- Show condenser fan speed in RPM
- Adjust audio alarm and relay trigger (NO or NC) based on: temperature, flow rate, coolant level, pump RPM, and condenser fan RPM
- Refrigerant: R-134a
- Power input: 220VAC, 50-60Hz (CEE 7/7 power cable included)
- Maximum power consumption @ ambient (approximate): 450W @ 25°C, 650W @ 35°C
- Designed for an operational temperature range of 0-40°C (ambient and liquid)
- Reservoir capacity: 3 liters
- NPT 1/4in threads on back for fittings

NOTE: Requires 220VAC, 50-60Hz input power. Keep unit upright at all times, and for at least 24 hours before applying power to ensure sufficient oil reaches the compressor.

General	
Weight	48.20 lb (21.86 kg)
Fitting Thread	NPT 1/4in
Max Pressure Tolerance @ 25°C	2kgf/cm2 (28.5psi)
Max Temp. Operating Tolerance	40°C (104°F)
Noise (dBA)	44-53
Cooling Systems	
Cooling Capacity	900W (3071BTU/hr) @ 25°C liquid & ambient (0°C dT)
Display Type	OLED

General	
Max Flow Rate (10-13mm ID)	11LPM (2.9 GPM)
Max Power Consumption	450W @25°C, 650W @35°C
Max Static Pressure (10-13mm ID)	0.9kgf/cm ² (13.2psi)
Power Source	220 VAC, 50-60Hz
Temperature Sensors	Liquid & One K-Type Thermocouple (optional)
Temperature Stability	+/-1°C

EXC-900 Pump Output

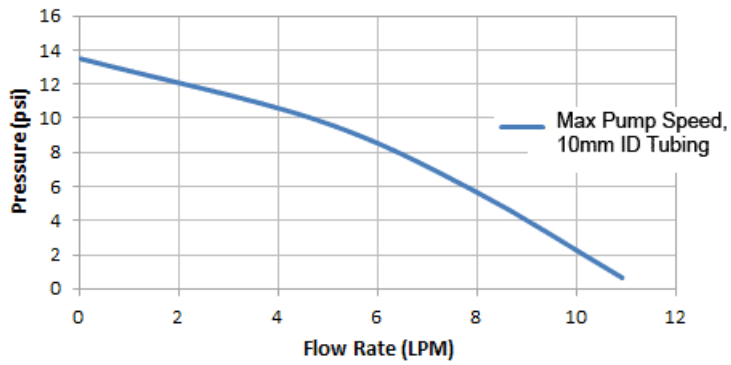

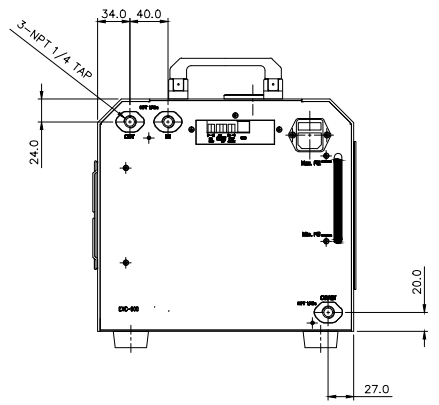
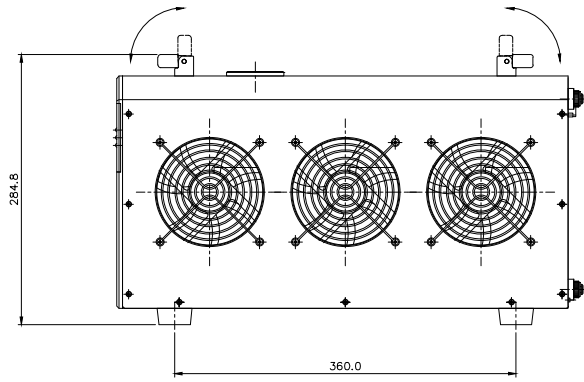
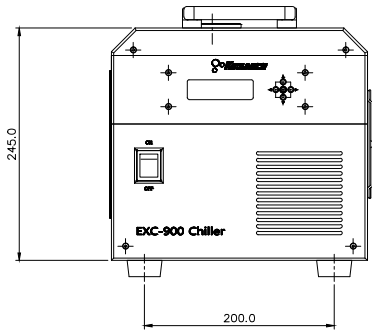
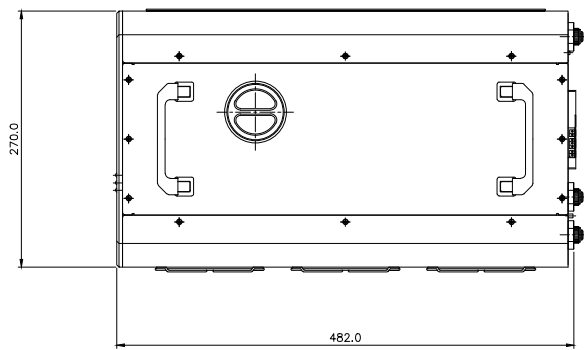
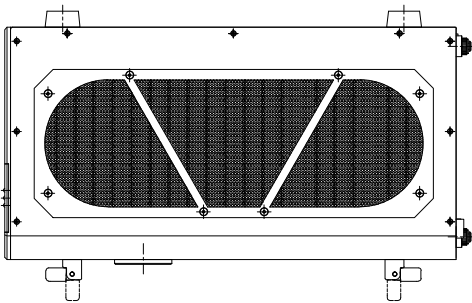

NO.	DESCRIPTION				MATER'L		QUANTITY	REMARKS
					UNIT	MM		
	KOOLANCE						ITEM	EXC-900
							SCALE	N/S
DATE	BY	BY	BY	APPRO	BY	3RD ANGLE		
	S.J.LEE				CODE NO.		DWG. NO.	PAGE