

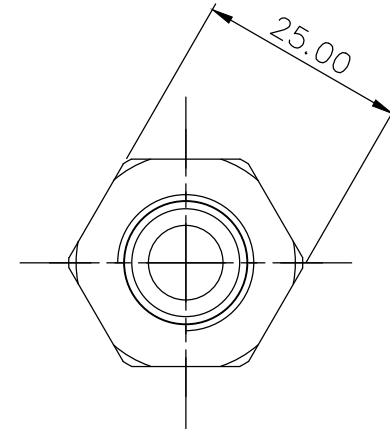

Thread adapter from NPT 3/8 (male) to NPT 1/2 (male).

General	
Weight	0.21 lb (0.10 kg)
Fitting Thread	NPT 3/8, NPT 1/2
Max Pressure Tolerance @ 25° C	15kgf/cm2 (213.4psi)
Max Temperature Tolerance	120° C (248° F)
Wetted Materials	Brass, Nickel Plating

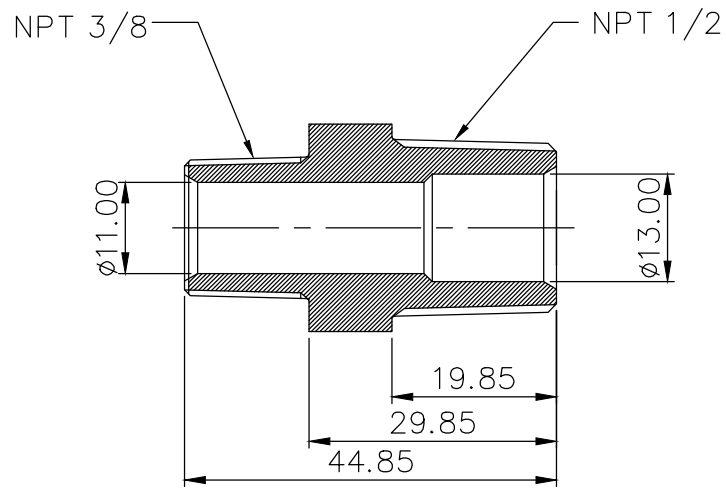
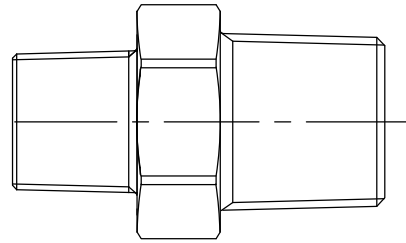

NO.	DESCRIPTION				MATER'L		QUANTITY	REMARKS
					UNIT	MM	PART NO. ADT-N38M-N12M	
					SCALE	N/S	TITLE	
DATE	BY	BY	BY	APPRD BY	3RD ANGLE		M-M Type (NPT3/8-NPT1/2)	
	ys.shin				DWG. NO.	ITEM		